



# I44v3

## High Performance Impact Crusher

The new I44v3 Impactor continues to bring high quality and high production capacity to McCloskey™ mobile impactor applications.

Efficiency is boosted with the I44v3 crusher design, particularly in the material flow path. Each sectional component is wider than the last to allow an unrestricted flow without funneling or narrowing, eliminating material bridging. The direct drive crusher rotor is also a new feature on the

I44v3, bringing more power, along with lower fuel costs.

The redesigned open chassis allows for better access, and a magnet contributes to easier operation of the crusher. The I44v3's versatility and upgraded design makes it ideal for some of the toughest applications worldwide, including aggregates, asphalt recycling, concrete recycling, mining, construction and demolition.

## Features

- 1050mm (41.3") diameter x 1125mm (44.3") wide Impactor
- 360Hp (268kW) Volvo D11 T4 Final engine
- Integrated hydraulic folding hopper
- I-beam plate fabricated chassis construction
- Open chassis design for ease of maintenance
- Fast setup time
- Track or Track c/w Wheel bogie.
- Integrated hydraulic folding stockpiling conveyors.
- Vibrating feeder under crusher discharge

## Material Flow Path

Each sectional component is wider than the last to allow an unrestricted flow of material without narrowing. Allows for reduced wear and eliminates material bridging.

## Crushing Chamber

A 41.3" x 44.3" (1050mm x 1125mm), four bar impactor rotor with a 45.2" x 27.9" (1149mm x 708mm) feed opening.

## Hopper

7.8 yd<sup>3</sup> (6m<sup>3</sup>) hopper features liners, hydraulic locking wedges, and side locking wedges that are easily operated from the ground.

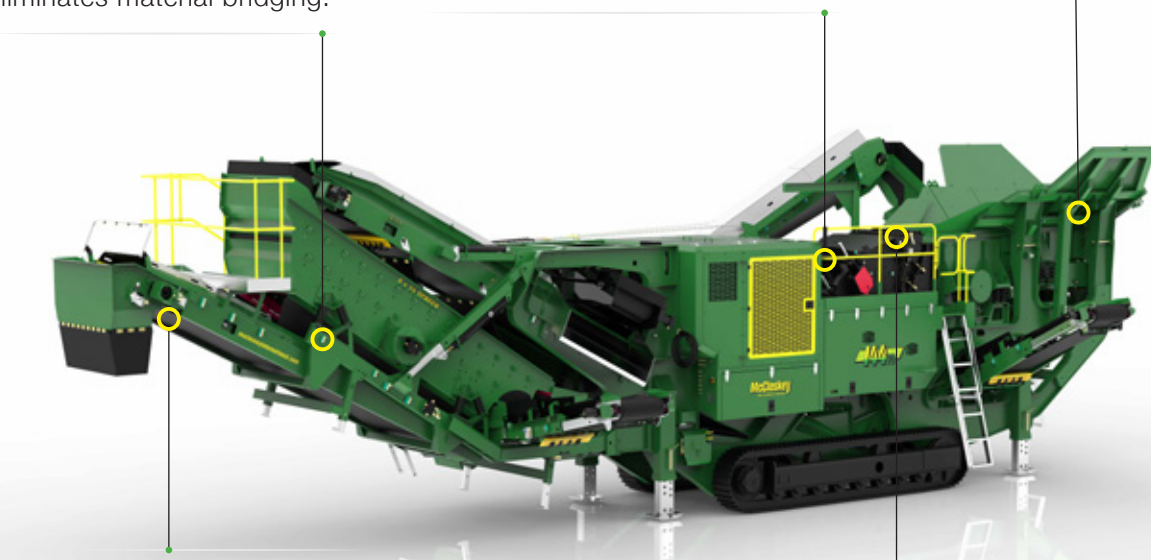

## 48" Main Conveyor

New wider 48" (1200mm) main conveyor, giving large stockpile capacity. Conveyor lowers and raises hydraulically.

## Crusher Rotor

Direct drive crusher rotor via clutch which boasts maximum power transmission with a low fuel cost.

## SPECIFICATION DATA

### Dimensions and Capacities

Engine	360 Hp (268 kW)
Transport Height	11' 1.8" (3.40m)
Transport Length	51' 4.9" (15.668m)
Transport Width	9' 1.5" (2.78m)
Weight - w/ magnet & dirt conveyor	92,594 lb (42,000kg)
Impact Rotor	41.3" diameter x 44.3" wide
Stockpile Height Main Conveyor	13' 7.1" (4.142m)
Stockpile Height Side Conveyor	8' 2" (2.49m)

©Copyright 2020 McCloskey International. All rights reserved. McCloskey is a trademark of McCloskey International.

McCloskey International reserves the right to make changes to the information and design of the machines on this brochure without reservation and notification to the users. Information at time of print considered accurate — McCloskey International assumes no liability resulting from errors or omissions in this document.