

Secoroc Rock Drilling Tools

# Product catalogue - Raiseboring equipment



*Atlas Copco*

# Unbeatable combination in raiseboring equipment

Atlas Copco Secoroc has an unbeatable technique when it comes to mechanical raise excavation – making large holes from 70 cm up to 6 meters in diameter. Flexible reamers, rigid saddles and durable stingers all add up to increased productivity.



Atlas Copco Secoroc provides a comprehensive range of raiseboring reamers for varying conditions. Reamer designs range from flat profiles (fewer cutters, lower torque) to barrel shaped profiles which provide better wear on transition rows and more protection for the gage cutters. We give you the choice of bolt-on or weld-on saddles, all made of rugged steel. Furthermore, our stingers are designed to withstand the high stresses that come with raise reaming. Once a stinger is damaged or worn, you can easily replace it using regular hand tools. What better way to prevent costly downtime?

## **Secoroc adds bite**

Secoroc is widely recognized as a leader in drill bit and button technology. We've now harnessed our know-how to optimize the performance of raiseboring cutters. Made of tough, wear resistant steel and fitted with carbide buttons, these cutters deliver outstanding performance in a wide range of rock formations.

## **We are wherever you are**

Atlas Copco Secoroc's unbeatable raiseboring technology is backed by our worldwide support network. Indeed, it's this unique blend of product performance and superior service – locally as well as globally – that sets our offer apart from its competitors.

## **The rock drilling tool specialist**

Over the years Secoroc has provided rock drilling tools to drillers throughout the world, often giving valuable tips in the process. So, we feel the epithet 'specialist' is well deserved. We've always been committed, and will remain so, to delivering the lowest cost per meter drilled. In that respect, you'll find our raiseboring equipment is no exception.

# Reliability and flexibility meets serviceability

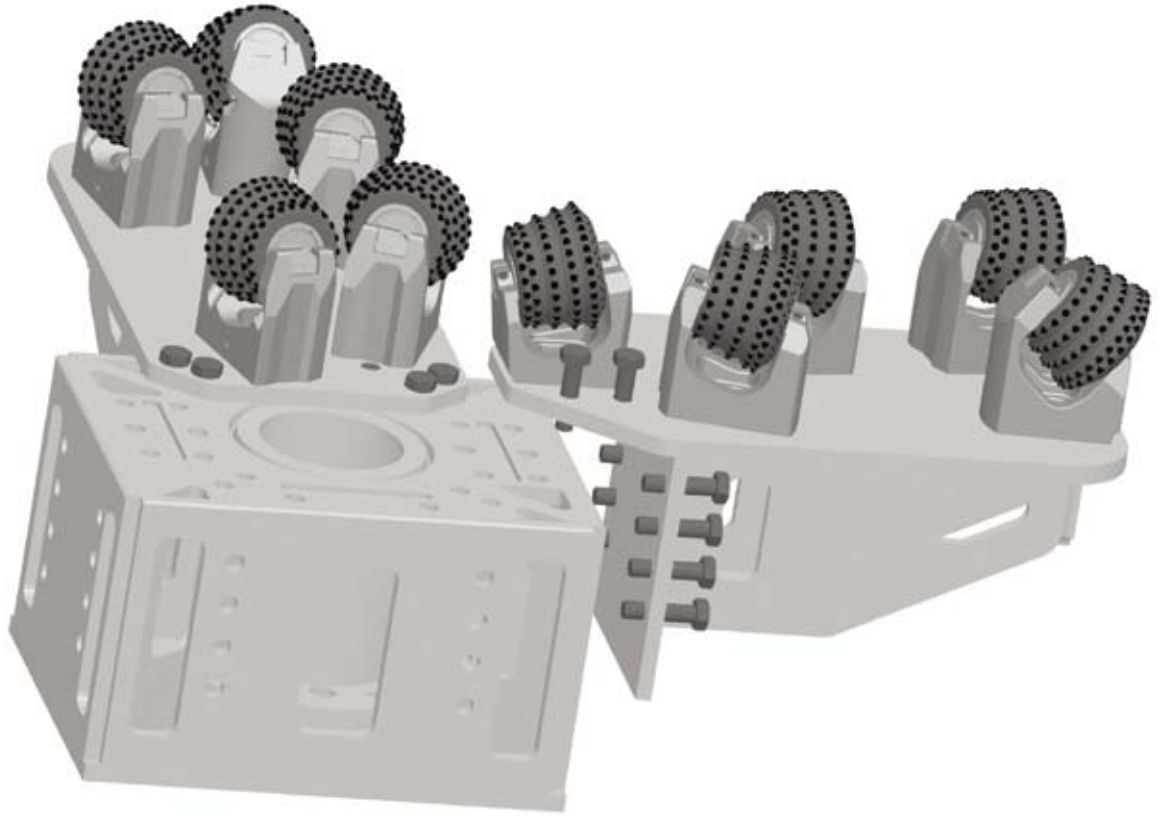

Rigid Secoroc reamer designs take punishment like a heavyweight prize fighter. Combine the most rigid design in the industry with rugged saddle designs and secure wing attachment and Secoroc's reliability is second to none.

With integral, expandable and specialty reamers, Secoroc Reamers can meet your requirements. Add selection of bolt or weld on saddles, profile design suited to the diameter no matter the size, and designs such as light weight, low profile integral reamers, multi-diameter combination boxhole and upreamer and expandable designs that can ream six or seven industry standard sizes – Secoroc designs are examples of flexibility.

Secoroc reamers are also designed for assembly from easy to access wing bolts; quick wing alignment methods; ability to hang wings before assembly; two, three or four wing designs; flanged stems; and available service help is a phone call away making serviceability paramount.

Matching Secoroc reamer designs with the best cutters in the industry make Secoroc the perfect blends of reliability, flexibility and serviceability, but the best is yet to come.

# Raiseboring reamers

Atlas Copco Secoroc reamers are available in a multitude of design types that include downreamers, boxhole heads, low angle reaming heads, raiseboring heads and specialty designed reamers for specific applications. In addition these reamers are available as integral designs (from 700 mm to 3.1 meters) and expandable or modular reamers from 1.4 meters in various sizes up to 6 meters in diameter. The reamers have a variety of design criteria to fit any application.

## RCC cutter reamer specifications

Reamer Model No		Number of Cutters	Reamer Diameter A (mm)	Reamer Dimension Without Cutters (mm)				Product Code
Basic	Extended			B min square	C min square	D	E	
RR2		2	692	645	335	-	1252	RRR-0692-ISR
RRB2		2	692	645	335	-	1168	RRB-0692-ISR
RRD2		2	692	645	335	-	1195	RRR-0692-ISR
RRH2		2	692	692	335	-	1354	RRR-0692-ISR
RR3.5		4	1046	1036	1036	-	1466	RRR-1046-SWR
RR3.5		4	1101	1082	965	431	1880	RRR-1101-BSR
RRB3.5		4	1060	1041	1041	-	1207	RRB-1060-ISR
RRD3.5		4	1060	1027	1027	-	1340	RRD-1060-ISR
RR4		5	1201	1182	1065	1166	1887	RRR-1201-BSR
RR4L		4	1311	1260	1041	984	1850	RRR-1311-BSR
RRH4		4	1311	1282	1224	1007	1945	RRR-1311-BSR
RR5		8	1519	1240	1069	997	1857	RRR-1519-BSR
RR5L		7	1524	1302	1175	1030	1819	RRR-1524-BSR
RR6		10	1833	1665	1451	997	1910	RRR-1833-BSR
RR7		12	2135	1591	1980	1072	1880	RRR-2135-BSR
RRS	Core			1778	1245	997	1880	RRS-BSR
	RR6E	10	1833	1665	1390	997	1880	XRS-1833-R
	RR6E7	12	2118	1819	1677	997	1880	XRS-2118-R
	RR6E7E8	14	2450	1996	1976	997	1880	XRS-2450-R
RRL	Core			2164	1003	1108	2135	RRL-BLR
	RRL8	12	2455	2164	1979	1108	2135	XRL-2455-R
	RRL10	16	3128	2730	2446	1108	2135	XRL-3128-R
	RRL11.5	18	3500	2819	2702	1108	2135	XRL-3500-R
	RRL12	18	3673	2838	2775	1108	2135	XRL-3673-R
	RRL12.6	20	3832	2958	2771	1108	2135	XRL-3832-R
	RRL13	20	4092	3187	2980	1108	2135	XRL-4092-R
RRH	Core			2164	1003	1531	2548	RRH-BLR
	RRH11.5	18	3500	2819	2702	1531	2548	XRH-3500-R
	RRH12	18	3673	2838	2775	1531	2548	XRH-3673-R
	RRH12.6	20	3832	2958	2771	1531	2548	XRH-3832-R
	RRH13	20	4092	3187	3010	1531	2548	XRH-4092-R
	RH14	20	4407	3432	3242	1531	2548	XRH-4407-R
	RRH15	24	4717	3809	3560	1531	2548	XRH-4717-R
	RRH17	26	5049	4037	3550	1531	2548	XRH-5049-R

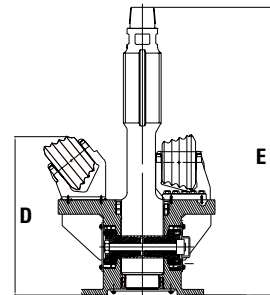
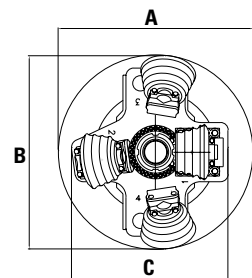



## Magnum cutter reamer specifications

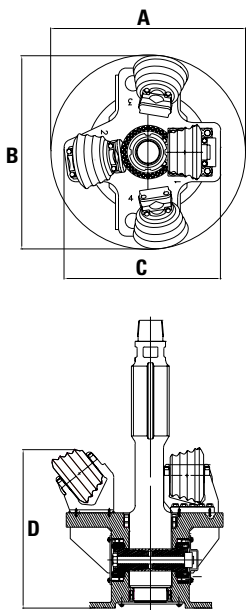

Reamer Model No		Number of Cutters	Reamer Diameter A (mm)	Reamer Dimension Without Cutters (mm)			Product Code
Basic	Extended			B min square	C min square	D	
RRR3.5		4	1066	1056	1056		RRR-1066-TSM-5300177
RRR3.5L		4	1066	1045	1028	746	RRR-1066-FSM-5002153
RRR4		6	1220	1119	1169	-	RRR-1220-TSM-5300180
RRR4.5		7	1372	1230	1281	-	RRR-1372-TSM-5300135
RR5UL		6	1529	1245	1384	962	RRR-1529-TSM-5300197
RRR5L		7	1524	1245	1384	962	RRR-1524-TSM-5002106
RRB5		7	1524	1245	1397	786	RRB-1524-TSM-5002122
RRR5		8	1524	1356	1372	975	RRR-1524-TSM-5300148
RRR6		10	1829	1524	1676	-	RRR-1829-FSM-5002113
RRR10		15	3048	2925	2925	1096	RRR-3048-FLM-5002089
RRA	RRA5	6	1524	1375	1375	-	RRA-1524-FSM-15390
	RRA6	9	1829	1605	1570	-	XRA-1829-M-15391
	RRA7	12	2134	1885	1800	-	XRA-2134-M-15392
RFO	RF04	5	1224	1118	1163	1092	RFO-1224-TSM-5300199
	RF05	8	1528	1176	1429	1092	XFO-1528-M-5200070
	RF06	10	1833	1625	1626	1092	XFO-1833-M-5200071
RFI	RFI5	8	1527	1136	1271	1044	RFI-1527-FSM-5002077
	RFI7	12	2137	1772	1907	1044	XFI-2137-M-5200002
	RFI8	14	2443	1973	2041	1044	XFI-2443-M-5200003
RSX	RSX6	10	1829	1562	1654	963	RSX-1829-TSM-5300130
	RSX7	12	2134	1806	1831	963	XSX-2134-M-6636
	RSX8	14	2438	1882	2172	963	XSX-2438-M-6668
RSE	RSE7	12	2134	1699	1958	-	RSE-2134-TLM-5300136
	RSE8	14	2438	2108	2132	1070	XES-2438-M-5200074
	RSE10	16	3050	2576	2891	1070	XSE-3050-M-5200053
	RMS (mini) Core	0	n/a	1067	1382	-	RMS-FLM-5002155
	RMS6	10	1830	2020	1705	1386	XMS-1830-M
	RMS7	12	2135	2154	1866	1386	XMS-2135-M
	RMS8	14	2438	2287	2025	1386	XMS-2438-M-5200035
	RMS9	16	2740	2288	2237	1386	XMS-2740-M-5200104
	RMS10	16	3048	2555	2346	1386	XMS-3048-M-5200043
	RMS12	18	3658	2937	2803	1386	XMS-3658-M
	RMS13.1	20	4000	3268	3268	1386	XMS-4000-M-5200086
	RMS14.8	24	4500	3755	3645	1386	XMS-4500-M

# Boxhole reamers

Atlas Copco Secoroc robust and well-designed boxhole reamers are popular among raise drillers around the world. We supply a full range of reamers from 0.7 m up to 2.4 m. Design range from integral to expandable. Some reamers are designed for multi purpose or multiple machines. Reamers available for use with RCC or Magnum cutters.

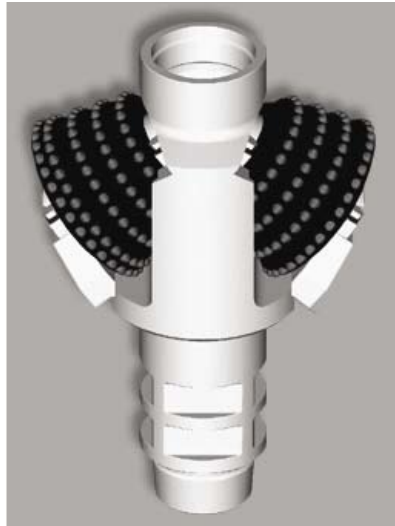

690 mm Boxhole reamer

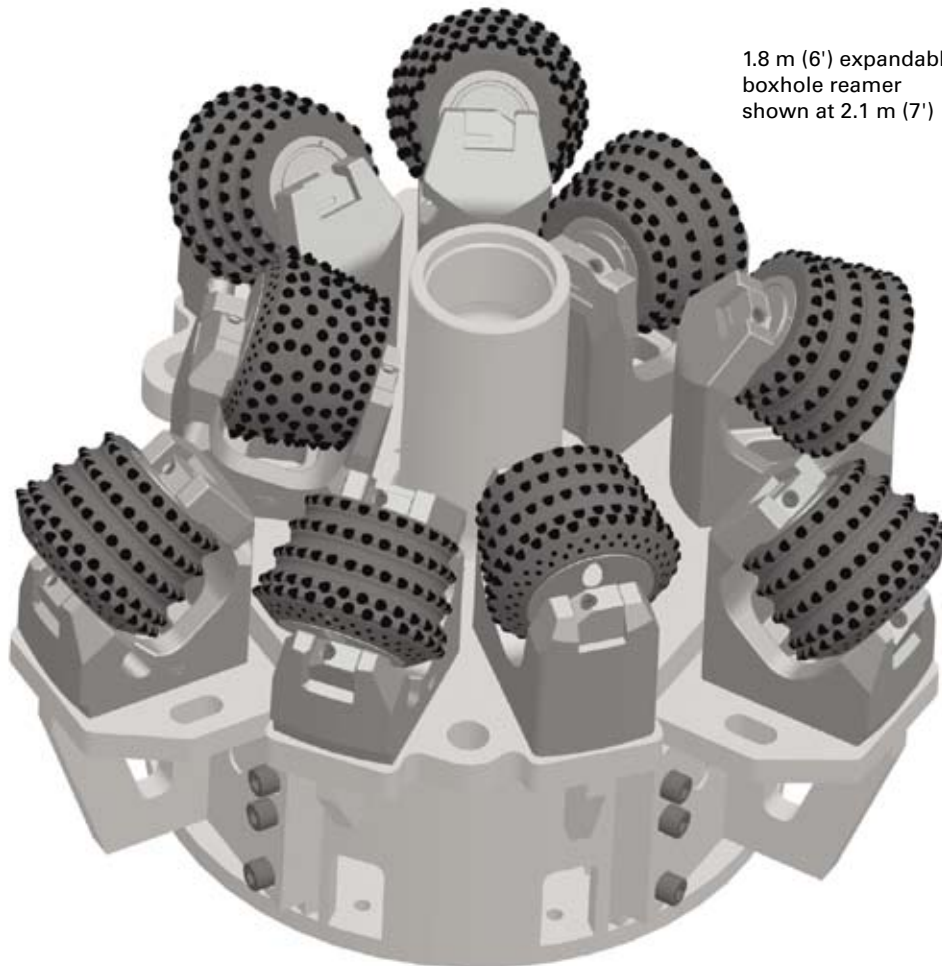

1.8 m (6') expandable  
boxhole reamer  
shown at 2.1 m (7')

# Integral reamers

Atlas Copco Secoroc series of integral reamers are basic, robust and well-designed. Integral reamers are available from 0.7 m to 3.1 m in diameter and with replaceable stingers for reamers over 1.0 m in diameter.

1.8 m (6')  
integral reamer

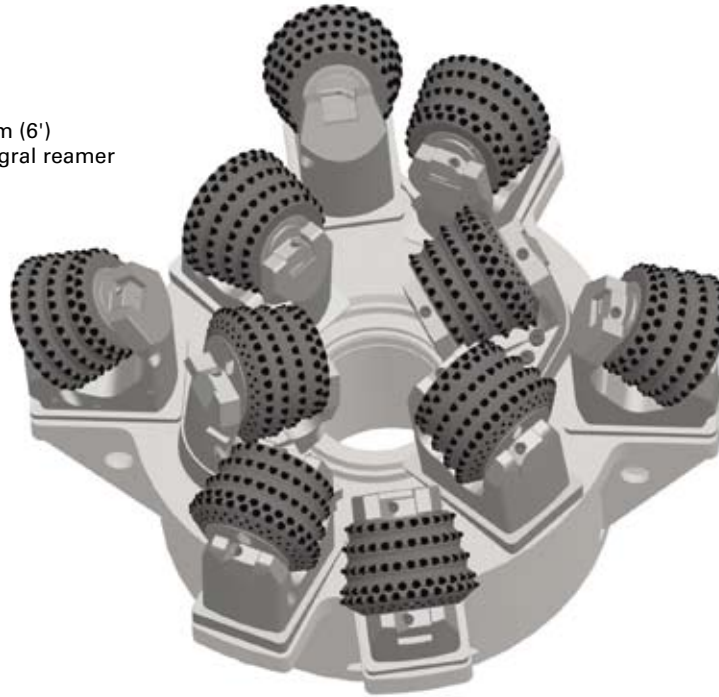

3.1 m (10')  
integral reamer

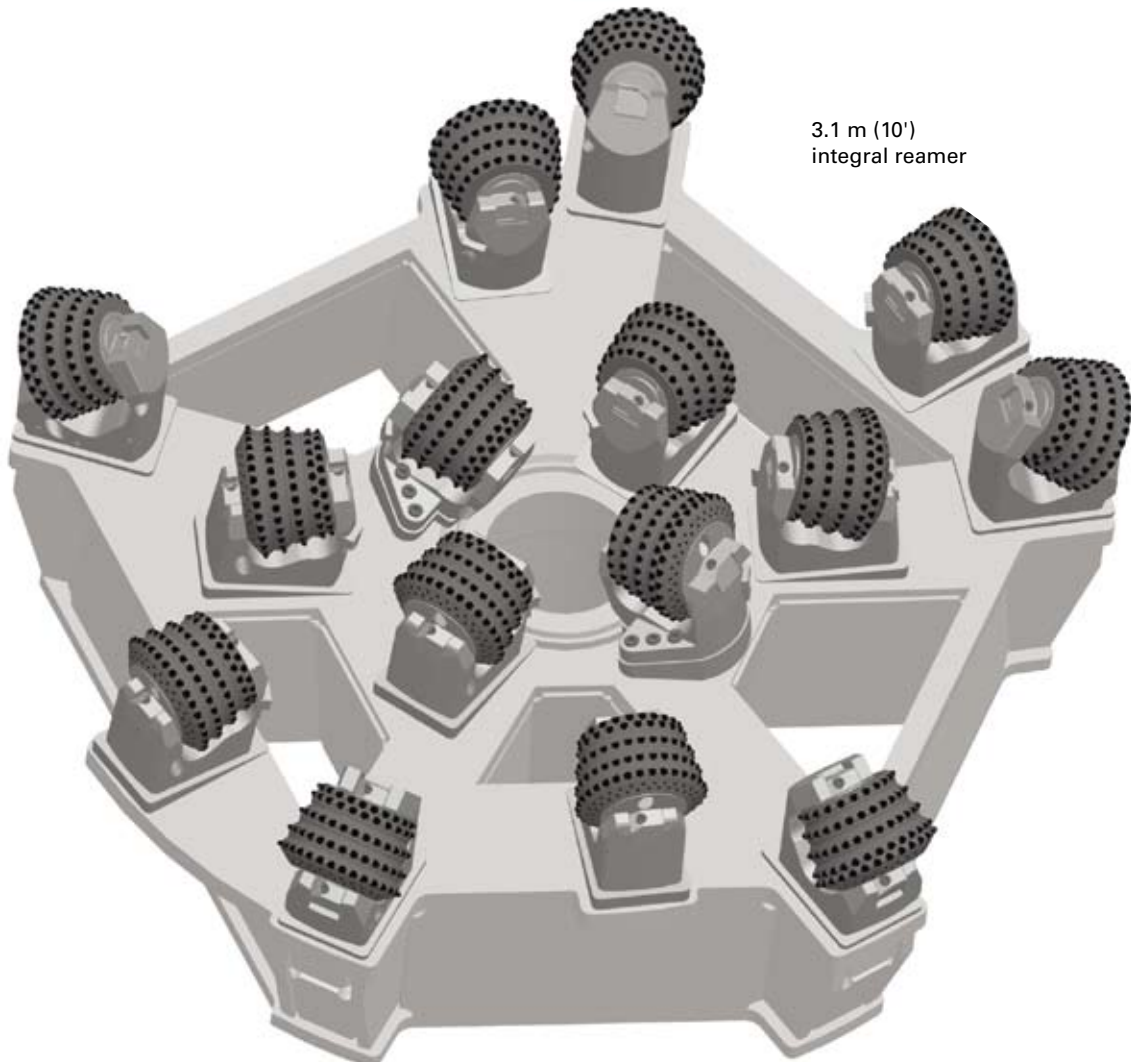

# Expandable reamers

Modular reamers for diameters from 1.8 m to 6.0 m. The modular design permits the reamer to be disassembled into several smaller pieces – including the stinger, the reamer core and the extension modules – for transport through restricted passages. The reamers are designed for easy removal of cuttings and the stingers and extensions are mounted and retained using heavy duty bolts and/or keys and dowels.

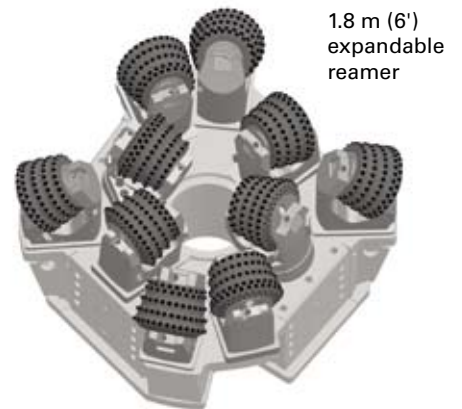

1.8 m (6')  
expandable  
reamer

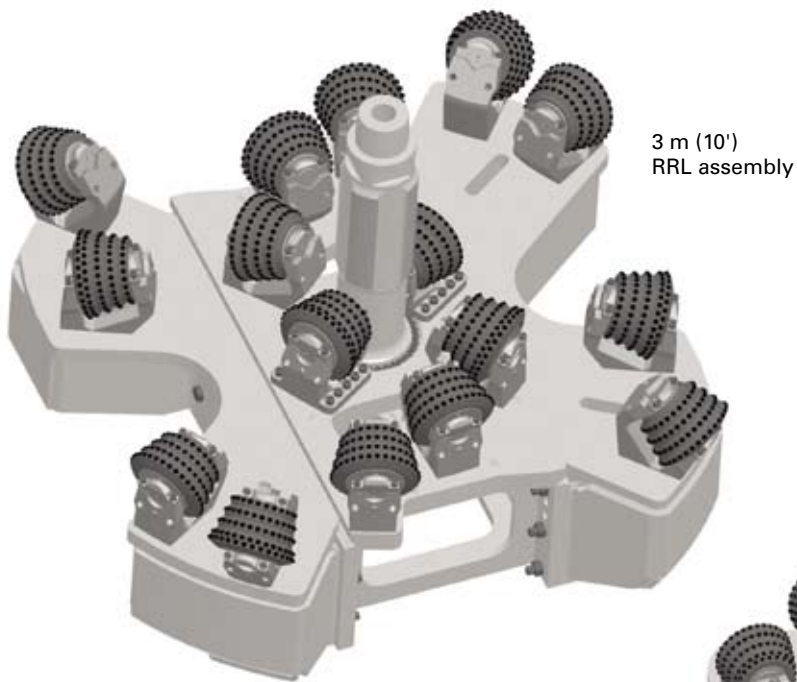

3 m (10')  
RRL assembly

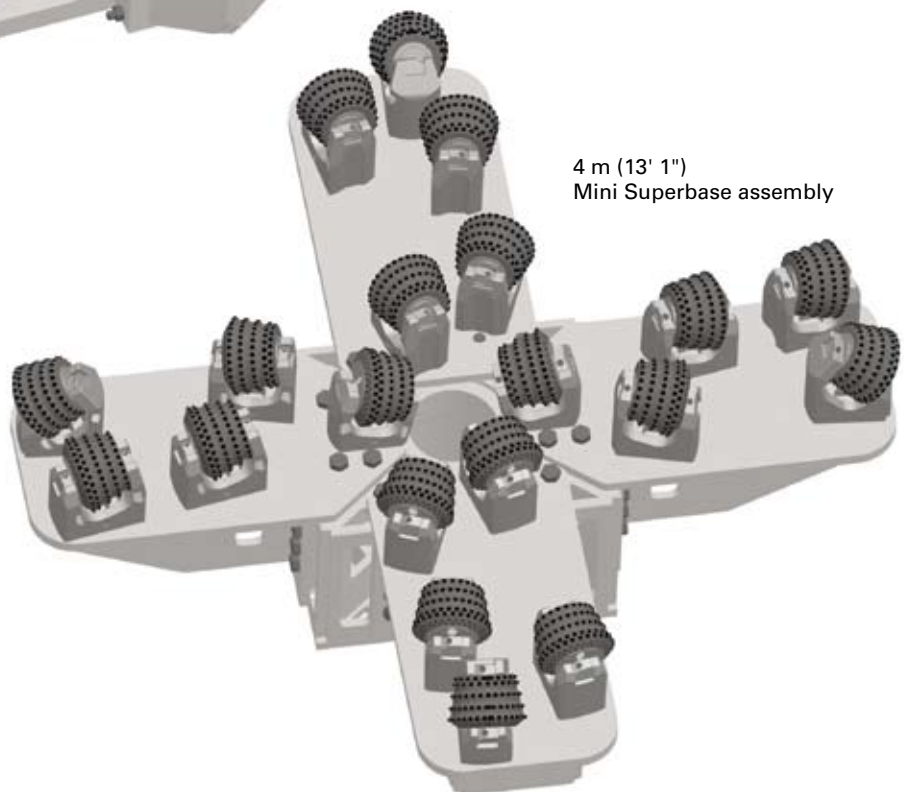

4 m (13' 1")  
Mini Superbase assembly



# Specialty reamers

Thanks to extensive R&D, we have the capacity and knowledge to offer specially designed reamers for unusual applications. Our designers work in close co-operation with our customers and our machine engineers to find the most profitable solution.

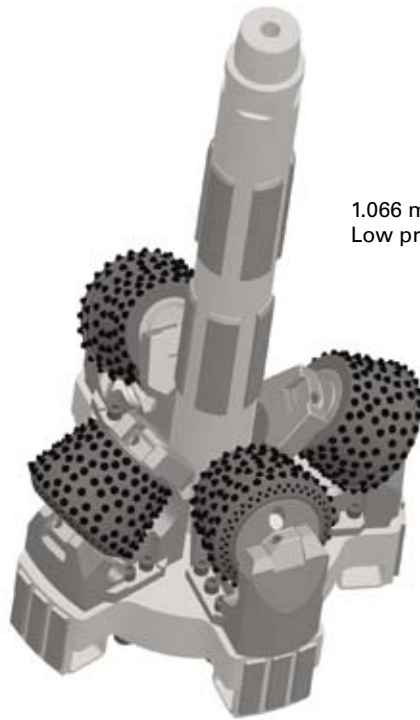

1.066 m (42")  
Low profile integral reamer

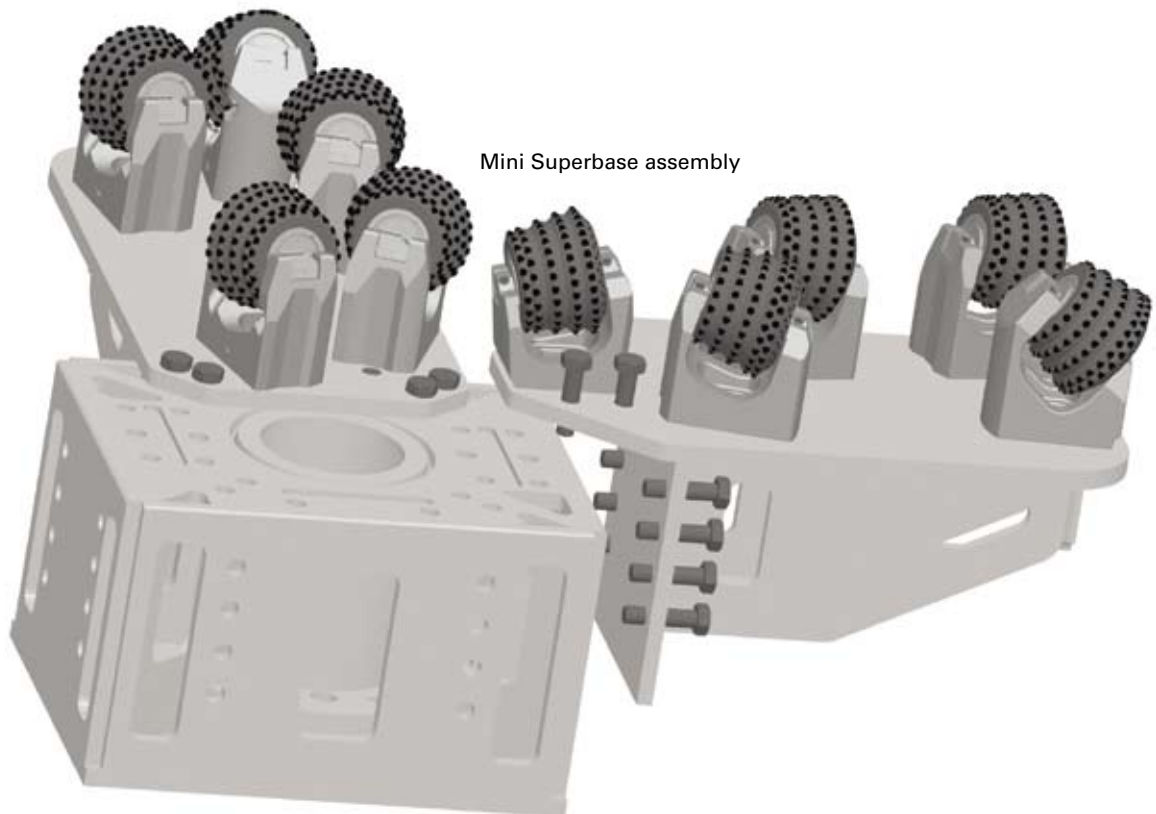

Mini Superbase assembly

# Down reamers

## Down reamers specifications

Reamer model No		Pilot Diameter	Numbers of Cutters	Reamer Diameter A	Reamer Dimesion Without Cutters (mm)				Product Code
Basic	Extended				B min. square	C min. square	D	E	
RRD720	N/A	9"	3	720	710	710	942	1192	RRD-0720-ISD-5107604403
RRR720	N/A	11"	3	720	710	710	942	1222	RRD-0720-ISD-5107604403
RRR770	N/A	11"	3	770	750	750	903	1450	RRR-0770-ISD-5107604813
RRD724	N/A	9"	3	692	710	710	905	1020	RRD-0724-SWG-5002148

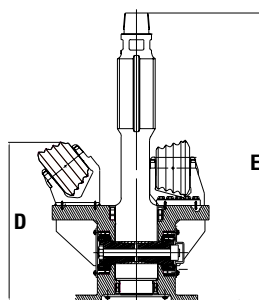
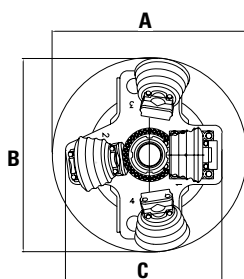

### 28.5" Down remers



# Raiseboring cutters

Atlas Copco's Secoroc raiseboring cutters come in a number of sizes to fit any need. The combination of the RCC product line and the Magnum product line provides a feast of choices to fill your raiseboring appetite. From kerfed cutters to rowed cutters to random cutters to specialty cutters the solution is yours to choose.



To support the insert and provide the best possible cutter retention, the cutter body has been manufactured using the highest quality alloy steel.

Atlas Copco Secoroc RCC cutters feature an internal pressure compensating device to protect the seal from excessive lubrication pressure and heat. And a pre-loaded tapered roller bearing provides maximum shock resistance.

Atlas Copco Secoroc Magnum Cutters feature the strongest bearing in the industry, the longest cutting structure and more carbide than any other cutter.

What's more, all parts in a cutter can be replaced if worn out to increase the total service life of the cutter.

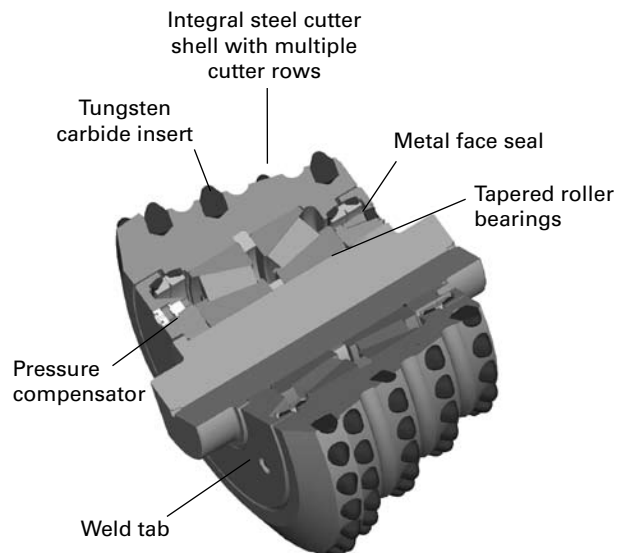

# Kerf cutters

## Kerf cutters specifications

Description	Product Code	Insert type	Weight	
			kg	lbs
RCC4 Cutter	CRC-4	Round Top Chisel	126	277
RCC5 Cutter	CRC-5	Round Top Chisel	130	286
MKC55G Cutter	CMC-5-G	Round Top Chisel	140	308
MKC55N Cutter	CMC-5-N	Round Top Chisel	140	308
SRCC4 Cutter	CSC-4	Round Top Chisel	121	266
SRCC5 Cutter	CSC-5	Round Top Chisel	125	275
MVKC55G Cutter	CVC-5-G	Round Top Chisel	140	308
MVKC55N Cutter	CVC-5-N	Round Top Chisel	140	308

### RCC Kerf Cutters

RCC Kerf Cutters are durable cutters designed for optimum penetration rates when the power is available for the job. The cutters can provide kerf spacing of 50 mm (2") using the RCC4 cutter, which provides the fastest penetration in soft and brittle rock, or 25 mm (1") using the RCC4 and RCC5 cutters in pairs for durability and fast penetration in medium to very

hard ground conditions. These cutters have a clean carbide row with more room for cuttings removal than any other design.



RCC4 cutter



RCC5 cutter

### Magnum Kerf Cutters

Magnum Kerf Cutters are designed for the tough drilling conditions. Each cutter has 5 rows of carbide and when run in pairs provide an extra row of protection on the nose and gage row of each cutter. Magnum kerf cutters can also be run staggered in some ground conditions where 2" of profile can be gained to reduce the number of cutters on the head. A modified 50 mm (2") spacing can also be employed by dressing the head with the 55G or the 55N for soft or brittle formations.



MKC55G

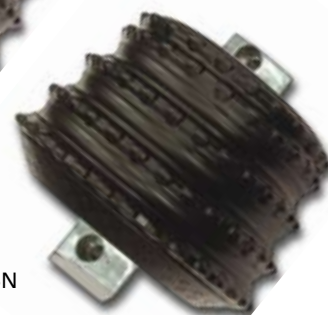

MVKC55N



# Cutters for non-Secoroc cutter retention systems



## Magnum V Cutters

Atlas Copco produces cutters that are designed to fit into the CMR saddle. The Magnum V is identical to the Magnum cutter except for the journal ends. This provides our customers with a cost effective option. The SRCC cutter is directly comparative to the standard cutter used in the CMR saddles.

MVKC55G



SRCC 4

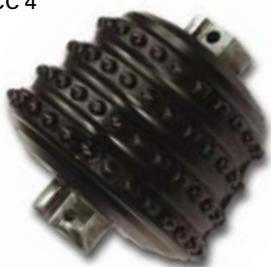

SRCC 5



MVKC55N



# Rowed and random cutters

## Rowed and random cutters specifications

Description	Product Code	Insert Type	Weight		Saddle type
			kg	lbs	
MR Conical Cutter	CNC-0	Conical	140	308	Magnum
RCC11	CRC-11	Round Top Chisel	135	297	RCC
RCB11	CRB-11	Ballistic	135	297	RCC
DRC12	CDC-12	Round Top Chisel	92	103	DRC
DRB12	CDB-12	Ballistic	92	103	DRC

Rowed Kerf cutters and random cutters are designed to optimize the power available at the reamer. For machines that are underpowered for the given formation these cutters provide smaller chips and faster penetration rates than the Kerf cutters in the same application. Rowed and random cutters are also designed to drill smoother than kerfs and require less torque to spall out cuttings.

Another rowed cutter that is also a specialty cutter is the DRC12 cutter which is designed for small diameter down reamers. With 12 rows and skip pitch spacing the cutter comes very close to a random cutting structure.



DRC 12 Cutter for small diameter downreaming applications.



RCC 11 Cutter – produces cuttings that range from narrow kerfs to chips



Magnum Random Cutter (MRC) produces large and small chips





**Atlas Copco Secoroc AB**  
Box 521, SE-737 25 Fagersta, Sweden  
Phone: +46 223 461 00  
E-mail: [secoroc@se.atlascopco.com](mailto:secoroc@se.atlascopco.com)  
[www.atlascopco.com](http://www.atlascopco.com)